

Taos Single-hole Basin Faucet
17-01

Installation Instructions



Tools You Will Need



Adjustable Wrench



Adjustable Pliers



Teflon Tape

For ease of installation you will need:

- To read the installation instructions completely before beginning.
- To read all warnings, care, and maintenance information.

Before beginning installation, check for any damage that may have occurred during transport.

Note: Damage claims cannot be made during or after installation.

Installation Instructions

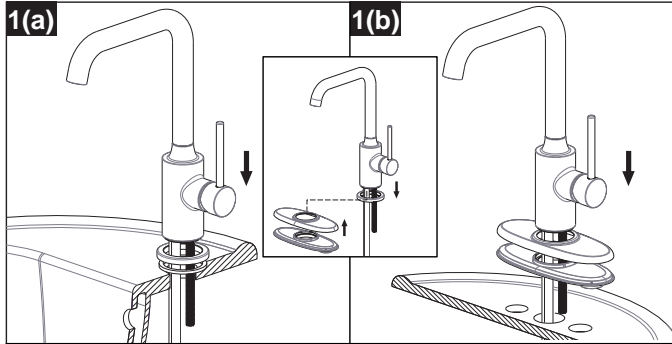

Lower faucet into mounting hole.
Plate in 1(b) is optional and may be ordered separately.

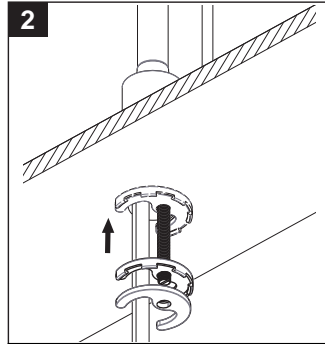

Slide "C" washer onto faucet shank.

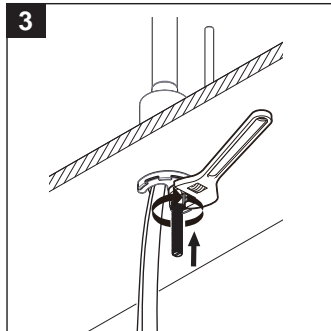

Carefully tighten spout nut to secure faucet.

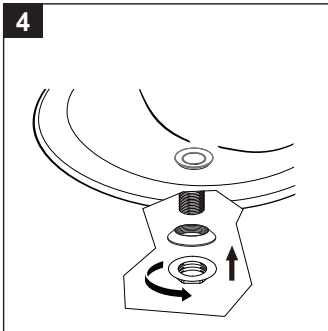

Slide push drain trim and plug into drain hole and secure from below.

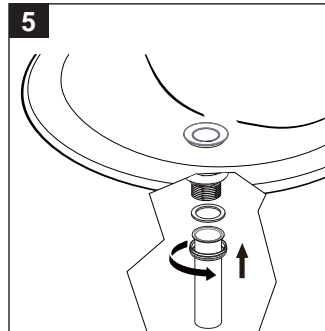

Install the drain tail piece to the drain plug.

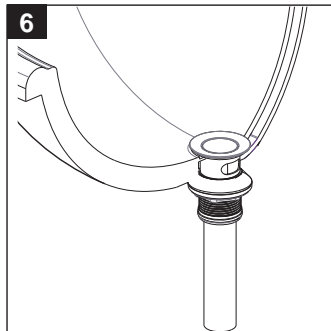

Push drain to test.

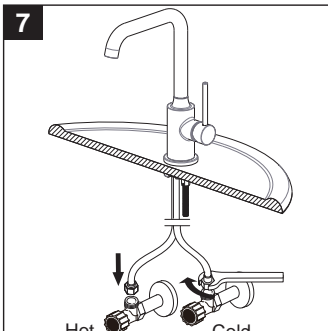

Attach water supply lines.

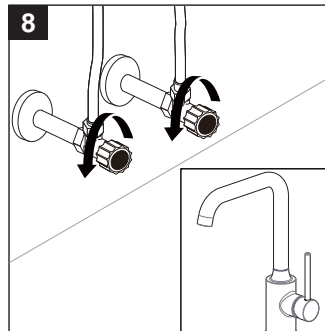

Turn on angle stops and check all connections for leaks.

9

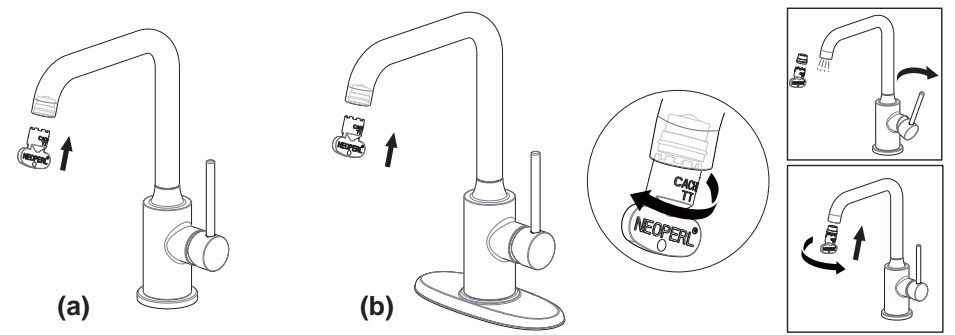

Remove aerator with key and flush out debris. Reinstall aerator and save aerator key for homeowner.

Cleaning Instructions

Rinse away any traces of soap and gently dry with a clean, soft cloth after each use. Rinse completely with water and dry any overspray. This will maintain the finish and avoid water spotting.

To remove mineral deposits, use a 50/50 solution of white vinegar and water. Do not allow the solution to soak on the product.

Simichrome Polish® contains a protective film to enhance maintenance and is helpful in preventing water spot buildup. Follow instructions to ensure optimum results.

Never use an abrasive material such as a brush or scouring pad to clean the surface. The use of abrasive cleaners, cleansers or disinfectants will alter the surface finish and void the warranty.

Do not allow certain materials such as toothpaste, cologne, shaving cream, nail polish remover, vinegar, wine, drain and glass cleaners to remain on the surface. Prolonged contact will alter surface finishes and void the warranty.

We DO NOT recommend using any household cleaners as many can cause damage to the finish.

Please see the website for care instructions for specific finishes.

Trouble-Shooting

If you have followed the instructions and your faucet still does not work properly take these corrective steps.

Problem	Cause	Action
Leaks under spout body	Loose water supply lines	Tighten all connections
Aerator leaks or has an inconsistent water flow pattern	Aerator is dirty or mis-threaded	Remove aerator with key and flush out debris. Reinstall aerator and save aerator key for homeowner
Only hot or only cold water is coming out of the spout	The hot or cold stop valve is not opened	Open the hot or cold stop valves
Handle will not move	Cartridge is dirty or mis-fitted	Remove, rinse and reinstall cartridge

Replacement Parts

NO.	Description	Part NO.
1	Aerator & Aerator Wrench	9Q252500PL
2	Push Drain Mounting Hardware	9Q0938NT
3	Push Drain Assembly	5Y0M0196
4	Supply Hose(Cold)	5G0M0068CC
5	Supply Hose(Hot)	5G0M0069CC
6	Lavatory Spout Mounting Hardware	9Q1140NT
7	Set Screw & Extra Allen Key	9Q1349NT
8	Cartridge	52007014PL
9	Deck Plate Assembly(Polished Chrome)	9Q1168CP
10	Deck Plate Assembly(Satin Nickel)	9Q1168AP
11	Deck Plate Assembly(Polished Nickel)	9Q1168RN
12	Deck Plate Assembly(Bronze)	9Q1168FO

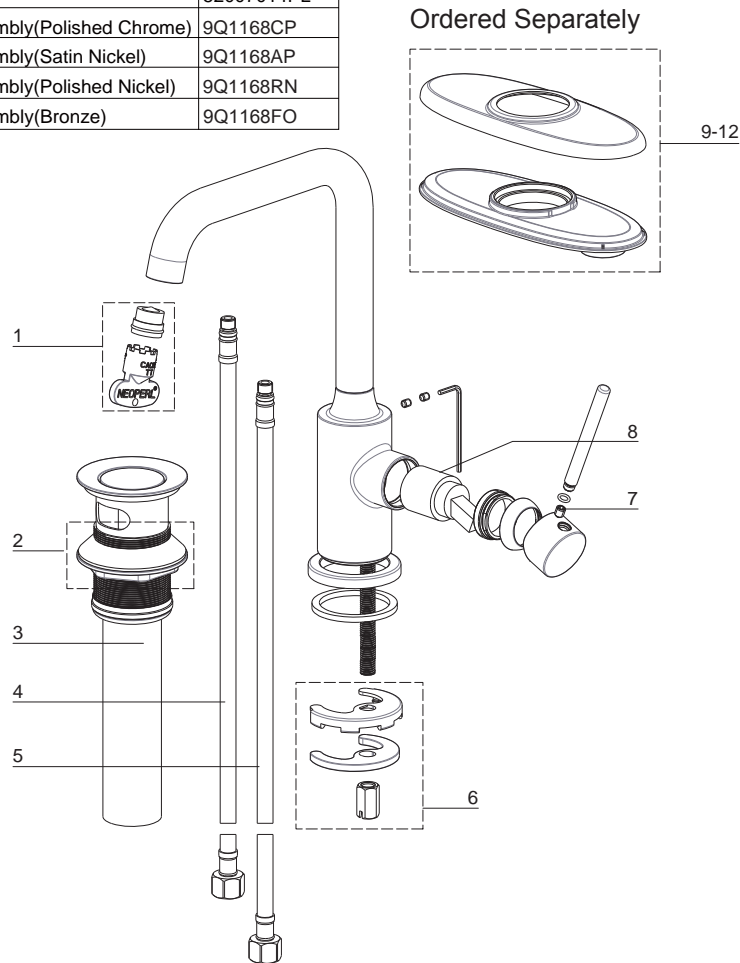

Applicable Standards/Codes

IAPMO certified to meet or exceed the following:

- ASME A112.18.1/CSA B125.1
- Uniform Plumbing Code
- National Plumbing Code of Canada
- NSF/ANSI 61
- Section 116875 of the California Health & Safety Code
- EPA WaterSense
- ADA Compliant



Installation Dimensions

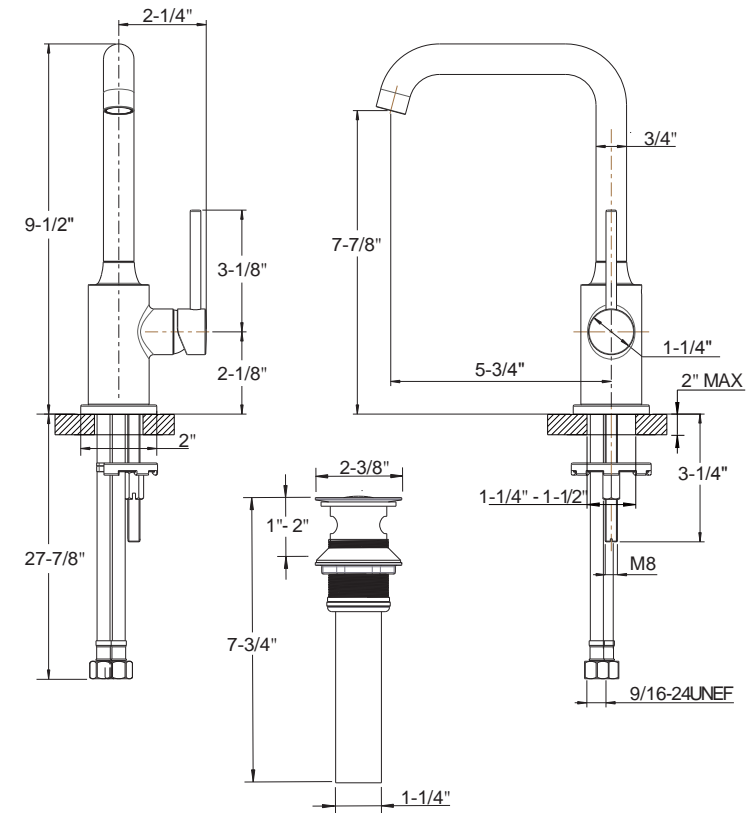

Warranty - This Crosswater London product is covered by a limited lifetime warranty. For full details, terms and conditions please visit our website. For further information contact: **Crosswater London**, 393 Fortune Blvd., Milford, MA 01757 www.crosswaterlondon.com
Toll free number: 844-XWATER-1 (844-992-8371) tel: 508-381-0433 fax: 508-381-6068 email: technical@crosswaterlondon.com